

Functional Testing of Electric Vehicle Battery Management Systems (BMS) using a PXI Platform

Grant Gothing
Project Engineer
Bloomy Controls
U.S.A.

The Challenge:

Design and develop a flexible and cost-effective test system for Battery Management Systems (BMS) balancing and management circuit boards. System requirements include simulating a pack of lithium-ion batteries, performing high accuracy voltage and current measurements, simulate telemetry and control signals, and communicating with the Unit Under Test via serial and/or CAN.

The Solution:

Create a flexible Battery Management System (BMS) test system which tests all necessary BMS functionality throughout the lifecycle of a product, from research and design, validation, verification, to manufacturing. Utilize commercial-off-the-shelf (COTS) hardware such as PXI instrumentation to shorten design time and ensure the system will provide the flexibility to expand capability, and provide the accuracy needed to test multiple customer products.

Overview:

The rapid growth of the hybrid-electric vehicle industry presents many new opportunities for product testing and measurement. Many of these opportunities require production level test systems with short design times, high accuracy and strong reliability. One such opportunity, discussed here, involves production testing of Battery Management Systems (BMS) for the lithium-ion battery packs which power Plug-in Hybrid Electric Vehicles (PHEV) and Electric Vehicles (EV). Battery Management Systems handle all of the monitoring, control, balancing, and safety circuitry of battery packs and control systems. BMSs accurately monitors cell voltages, balances the voltages between the cells to maintain a constant pack voltage, manages charging and discharging, and protecting the system from over-voltage and over-current conditions for packs of cells in series. In addition, these systems monitor system temperatures, handle system power saving (by entering sleep modes to reduce current draw), and communicate with external controllers to provide system feedback. While there are several types of battery management system boards and architectures, including individual pack balancing and monitoring boards, and system control boards, we refer to them all as BMSs in this document.

BMS Features and Requirements

Because the BMS is so important to the safety, performance, and longevity of hybrid vehicle batteries it is critical that each manufactured board performs to strict specifications. Cell voltages must be monitored to milli-volt accuracy, safety faults must occur properly, and the BMS must draw current from individual cells to balance voltages across a whole pack. Functional test of these processes requires a highly accurate, flexible, robust test system capable of simulating packs of cells, applying system

voltages, measuring cell and system-level voltages and currents, and communicating with the Unit Under Test (UUT).

System Hardware Design

By starting with their PXI-based Universal Test System, we at Bloomy Controls produced a flexible, high accuracy base platform, consisting of a standard mass-interconnect capable of testing multiple models of BMS circuit boards by utilizing interchangeable fixtures. The system was centered upon National Instruments' PXI-4110 Triple-Output Programmable DC Power Supplies which are used to simulate a pack of lithium-ion cells. A high accuracy 7.5-digit DMM was multiplexed to measure voltages within the required milli-volt specifications, and a multifunction DAQ card was added to the system to provide analog outputs, TTL digital inputs/outputs, and higher speed analog input measurements. In addition to the PXI hardware, fixed power supplies and programmable high voltage and high current supplies were used to provide additional system power as required by testing specifications. Finally, a USB connection was provided to the fixtures to allow flexible addition of other UUT specific communications and peripheral hardware on a per-model basis. All hardware was housed in a standard 19" rack. The test rack provided a system capable of making any measurement and supplying any source required by a BMS board.

A standard fixture receiver was used to permit several different BMS designs to be tested using the same base hardware. Each fixture type was electronically keyed, guaranteeing that the correct test code would run for the attached fixture. Using interchangeable fixtures greatly reduced system cost and lead times by sharing key instrumentation hardware among UUTs. Once the base system was built, new fixtures and their associated test software could be designed and built very quickly. Figure 1 shows the base system as it was delivered to the customer.



Figure 1: BMS Tester Base System

Series Cell Simulation, Based on the PXI-4110

In order to simulate a pack of lithium-ion cells, the isolated +/-20 V legs of the PXI-4110 supplies were linked together in series, as shown in Figure 2; each leg simulated a single cell of the pack. During cell voltage testing, the power supplies would apply individual cell voltages between 2 V and 4 V; the system can handle up to 24 unique cells. The software would then poll the UUT for its reported voltages seen at each cell; these voltages would be compared to the voltages measured by the DMM in the test system to determine UUT accuracy. For tests measuring each cell's balancing current, the 16-bit readback resolution of the PXI-4110 supplies was vital because it eliminated the need for external shunt or hall effect current. Overall, the PXI-4110 was an excellent choice for this application due to its low ripple, fast response, high resolution, and ease of control.

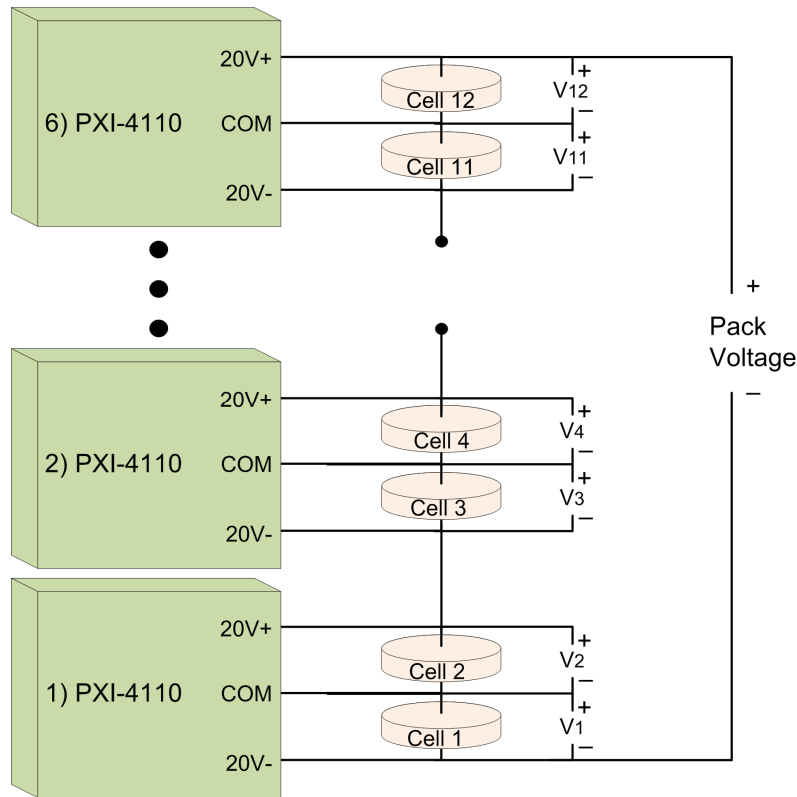

Figure 2: Series Cell Layout using the PXI-4110

System Software Design

The test software was written using National Instruments LabVIEW and TestStand. All test parameters were contained in a configuration file to allow the customer to update, tighten, or loosen test specifications without making software changes. In addition, all data acquisition channels and tasks were stored in a separate configuration file allowing hardware or wiring changes to be made without affecting the underlying software. The user interface is designed for a manufacturing environment, and requires minimal operator interaction. During standard operation the test technician simply opens the safety lid of the fixture, scans the barcode serial number of the unit to test, then closes the fixture, and the test starts. When testing is finished, the test result is shown, test data is logged to file, and any failed tests are highlighted for the technician.

All software was also delivered with debugging and diagnostic modes which provided engineers more manual control over the system. The debug mode allowed test engineers to run smaller subsets of the main test to narrow down the possible causes of a failure. The diagnostics control screen provided access to all aspects of the system pertaining to the attached fixture. This allowed the engineer to manually read all system voltages and currents, control all power supplies, actuate relays, and communicate with the UUT.

An Accurate, Flexible Testing Solution

The PXI platform, and modular instrumentation used in the BMS Functional Test System was critical in designing an accurate, easy to use, and flexible test system. The series connected PXI-4110 Programmable DC Power Supplies were ideal for simulating packs of lithium-ion cells. To date, Bloomy Controls has delivered over five (5) base systems and fifteen (15) fixtures for unique BMS models. Two of the base systems were delivered directly to contract manufacturers, one of which is currently located in China. By using a modular approach and interchangeable components, the base system can accommodate testing a wide range of BMS models and allows the flexibility of adding features. This method reduces cost and new fixture design time, and makes it cost effective to test even small quantities, such as R&D prototypes. Bloomy Controls' experience with BMS testing allows for the rapid development of new test systems with low risk and short lead times. In summary, the PXI platform provided us the ideal tools to quickly design and build a test platform for Battery Management Systems that is flexible enough to test multiple customer products, and accurate enough to meet or exceed BMS testing requirements.