

Superior Measurements with a PXI Differential Amplifier

By Adam Fleder, President, TEGAM

Why Make a Differential Measurement

Making an accurate measurement requires an unbroken chain of signal integrity from the point of connection through the conversion to a numerical value. This article concerns itself with the initial connection and immediate circuitry that conveys the signal of interest to the measurement system. There are many signals of interest in the circuits and systems in existence today that cannot be effectively measured with a single ended connection. A single ended connection is defined as one point referenced to a general ground plane. In contrast, a differential measurement is made between two points that may or may not be at ground potential. This provides obvious advantages when both points are separated from ground but also acts to reduce noise in all measurements even when the point of interest is referenced to local ground. In many circumstances, digitizers and oscilloscopes are limited by their single ended input circuitry which limits their ability to yield a useful measurement or worse, entices users to compromise safety in order to acquire an accurate signal.

Single Ended vs. Differential Measurement

In reality, all signal measurements are differential in that the measurements are always made between two points. The convenience of a common ground reference allows the engineer to make the simplifying assumption that ground is uniform and that all signals referenced to it are accurate representations of the actual signal. However, higher operating frequencies for analog and digital circuits, make this assumption less and less valid. In addition, many measurements need to be made where neither point is close to ground potential. Figure 1 details a standard full bridge switch mode power supply circuit that demonstrates the limitations of a single-ended measurement.

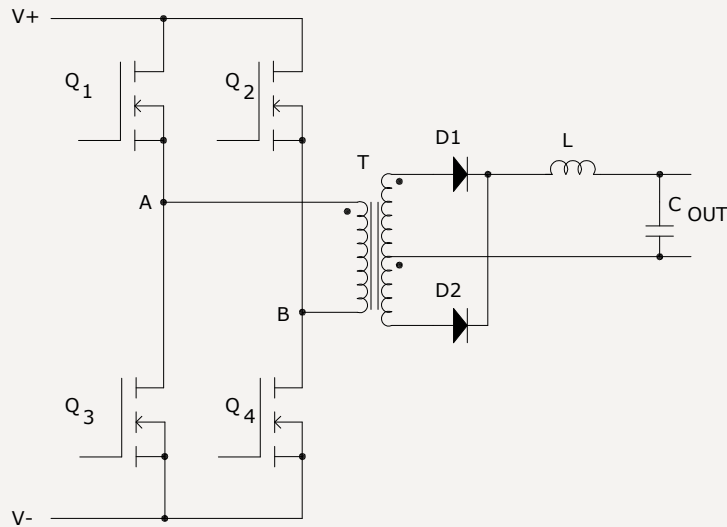

Figure 1

Referring to Figure 1, to measure the signal from point A to point B requires making a choice between three approaches.

1. Disconnect the ground of the measurement instrument and connect the input to point A and the measurement ground to Point B. Note: this is not a recommended practice due to the hazards of electrocution.
2. Use two measurement channels and measure at point A and B of the load and use the math functions of the instrument to compute A-B.
3. Apply a differential amplifier to measure only the difference between points A and B.

Now, let's look at the complete measurement circuit and performance of each of these options.

Isolating (Floating) the Instrument

Most anyone who has used a scope in their daily work has used this dangerous practice. The main input power cord is modified or an adapter is used to disconnect the main power input ground. This enables the instrument to be connected to the circuit points A and B in Figure 1. However, the case of the instrument becomes the potential of point B and exposes the operator to potentially lethal voltages. Often we feel we can manage this danger and proceed to make measurements in this manner. What is less understood is the degree to which this compromises the measurement. Instruments are not actually designed

to perform in this manner and unexpected circuit paths exist that distort the signal being measured. This distortion typically increases with frequency. Figure 2 represents a simplification of the circuit paths created when the instrument is theoretically isolated. Points A & B represent the same points as in Figure 1. Even though the instrument is disconnected from earth ground a capacitive coupling (C_{ps}) to the power line through the instrument's internal power supply is present which appears as a load on the ground lead which is connected to point B. In this case, the circuit is completed through the input terminals of the switch mode power supply being tested. This parasitic load capacitance on point B is what affects the measurement. Additionally, depending on what other test equipment or hardware is connected, other parasitic loads and circuit paths will exist so the exact behavior of the measurement is not necessarily predictable or repeatable.

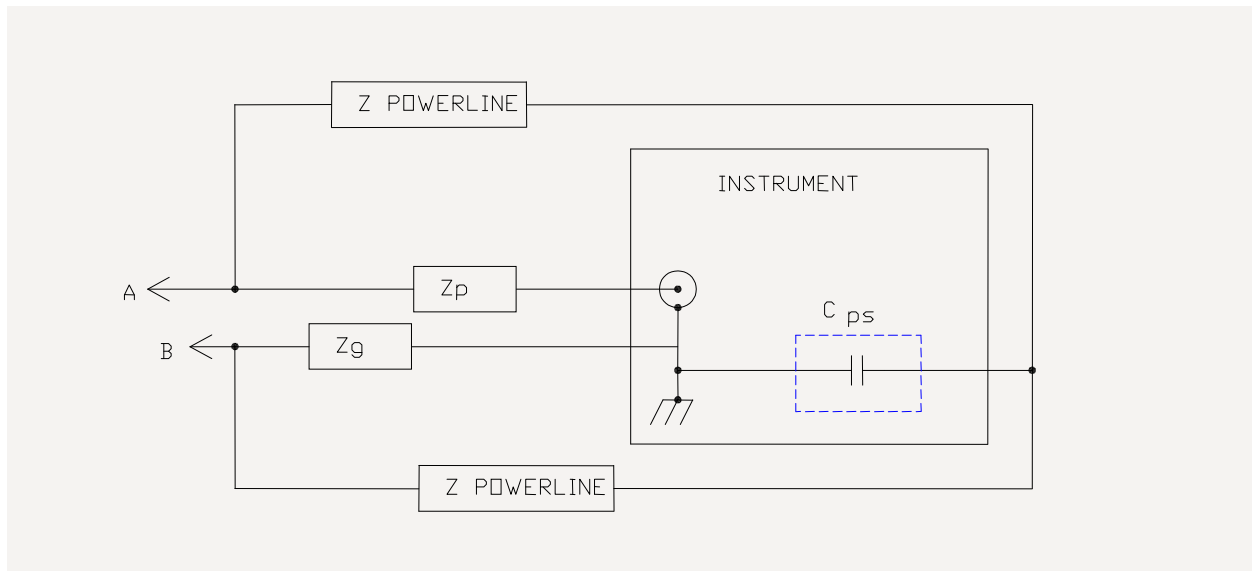

Figure 2

The types of measurements that can be made are also limited when an instrument is connected in this fashion. Referencing the instrument to a point other than ground means that any other measurement must also be referenced to the same point. For example, in the circuit of Figure 1, there are many other points of interest that a designer would like to observe simultaneously but do not share a common ground. More particularly, it is common to be interested in MOSFET gate drive while simultaneously observing the waveform on the primary of T. This cannot be done when the instrument can only be referenced to a single ground point. Unless one is using a scope with isolated input channels and a high voltage probe, these types of measurements cannot be done safely or accurately.

Mathematically Computing the Difference

Most modern digital scopes and digitizers include the ability to take the signal from two channels and compute the difference. Referring to Figure 1, a measurement channel would be connected to point A and another would be connected to point B with appropriately rated probes. The ground would be connected to the system ground to properly protect the operator from exposure to hazardous voltages. The two resulting signals are then subtracted to reproduce the wave form between points A & B. This works relatively well when the difference waveform amplitude is a large proportion of the individual input channels. However when the difference is relatively small, the resolution of difference waveform is very low. The reason for this is found in the dynamic range of the A/D conversion process in the instrument. Let's assume that we are measuring 100V signals on each input channel and the difference signal of interest is 1V. Each input channel must be scaled to capture the entire 100V signal. That leaves the difference to be only 2 counts for an 8 bit of conversion resolution ($1V/100V*255$). Increasing the conversion resolution to 12 bits still only yields 40 counts ($1V/100V*4095$) for the difference waveform.

Additionally, the effects of Common Mode Rejection Ratio (CMRR) must also be considered. This is a key specification when making a measurement that is referenced to a point of changing voltage. Again referring to Figure 1, if point B is changing based on the state of the switching transistors Q1-Q4, point B will be nearly equal to V+ when Q1 and Q4 are turned on and then point B will be nearly equal to V- when Q2 and Q3 are turned on. The goal is to measure the difference between points A and B and ignore the signal that is common to both. The CMRR specification quantifies the amount of this common signal that contaminates the measurement. CMRR is dependent on the gain match and the time synchronization of the two input channels from which difference is computed. Total gain accuracies of +/-1% are fairly standard among manufacturers of oscilloscopes and digitizers which results in a system CMRR specification of 34dB (50:1). For example, in power supply or medical device applications it is often the case that a small signal needs to be amplified in the presence of a large common mode voltage - a 34dB CMRR specification would produce a resultant signal that contains equal parts of signal and noise. Consequently, a differential amplifier can provide a superior measurement.

Using Differential Amplifiers

A differential amplifier is the key to a superior measurement for signals that cannot be directly referenced to ground because it enhances safety while producing a better signal measurement. Figure 3 is a block diagram of TEGAM's new model 4040A 50MHz PXI differential instrumentation amplifier. This type of instrument is safer to use because it re-references the measured signal to the earth ground of the instrument system. Re-referencing the measured signal also allows measurements to be made simultaneously at points relative to different voltages in a circuit. Another measurement advantage of the differential amplifier is that both input signal paths are matched, resulting in CMRR specifications of 80dB (10,000:1) or higher. This produces much better signal to noise ratios than is achievable by mathematically computing the difference between two channels. The design of the differential amplifier also rejects the common mode signal prior to amplification so that the signal of interest can be more closely matched to the digitizer input channel resulting in a much higher dynamic range.

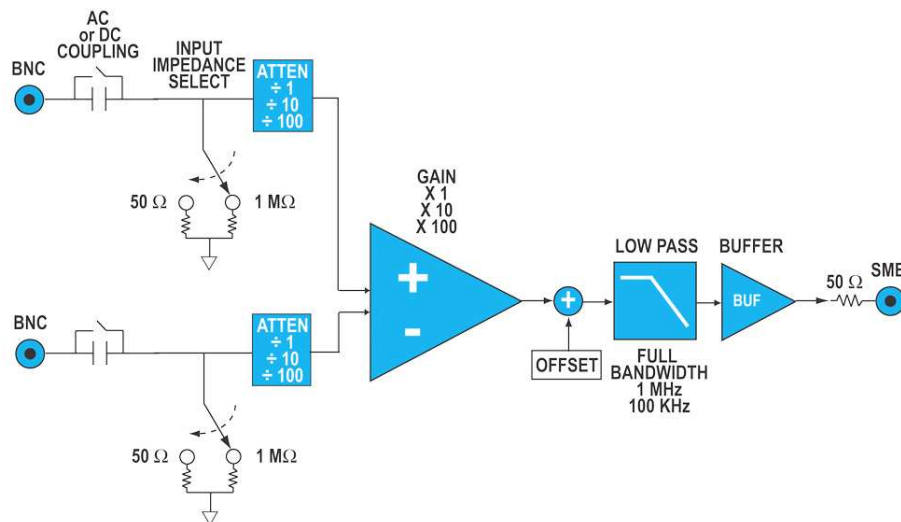

Figure 3

The TEGAM 4040A shown in Figures 3 and 4 is designed for use in PXI instruments chassis and all of the features are controllable over the PXI bus for remote operation. Often increasing performance increases cost, however this differential amplifier can actually reduce the cost of making a measurement by reducing the number of input channels required to capture a signal - freeing up valuable digitizer channels for other uses.



Figure 4

Conclusion

Differential amplifiers can offer a superior solution for conveying a signal with the highest integrity from the point of measurement to the instrumentation system. Not only can better measurements be made but they can be made safely, more flexibly and more cost effectively.