

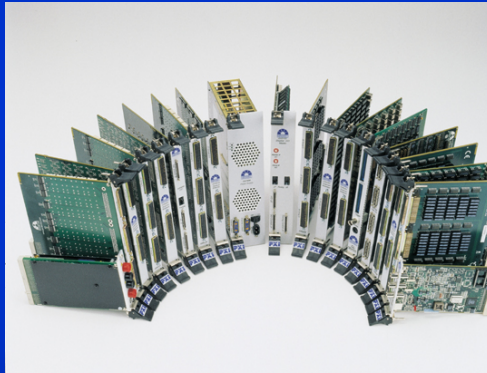

# Modular Instrumentation



Presented by the



# Agenda

- **PXI Overview**
  - Where it fits - Where it comes from
  - Architecture
  - Based on Open Standards
  - Market Size/Growth
  - Summary



# PXI Modular Instrumentation

- Uses PC SW and HW Technology:
  - Low Cost
  - High Performance
  - Ease of Use
- **Modular**, Rugged Form Factor with more slots
- Built-in **Instrumentation** Features



# Filling the Gap

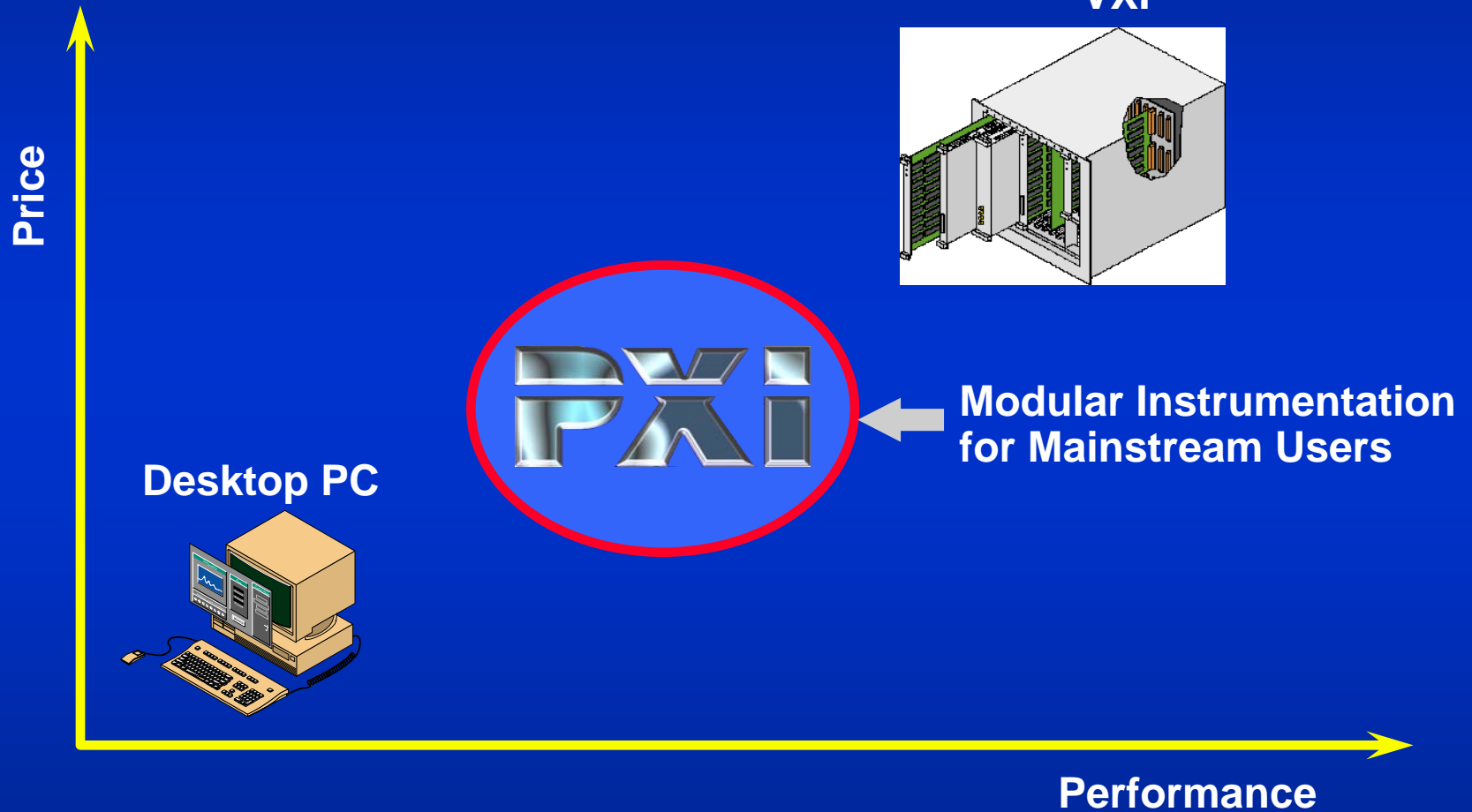

# PXI Combines Standard Technologies

PXI

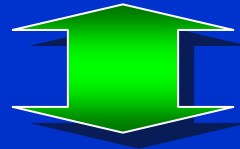
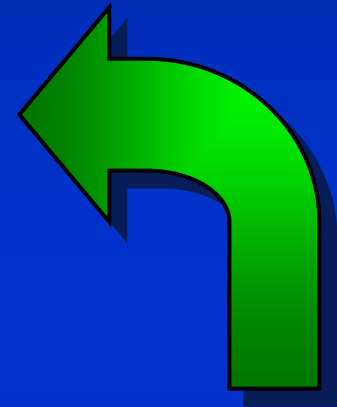
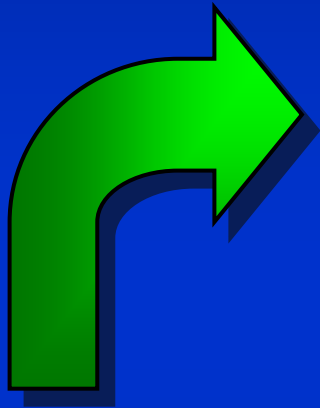

*CompactPCI*

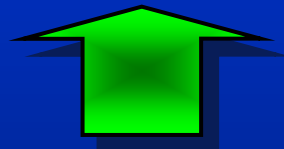

PXI

*PCI*

# A Closer Look at PXI

The PXI system specification extends CompactPCI for Instrumentation.

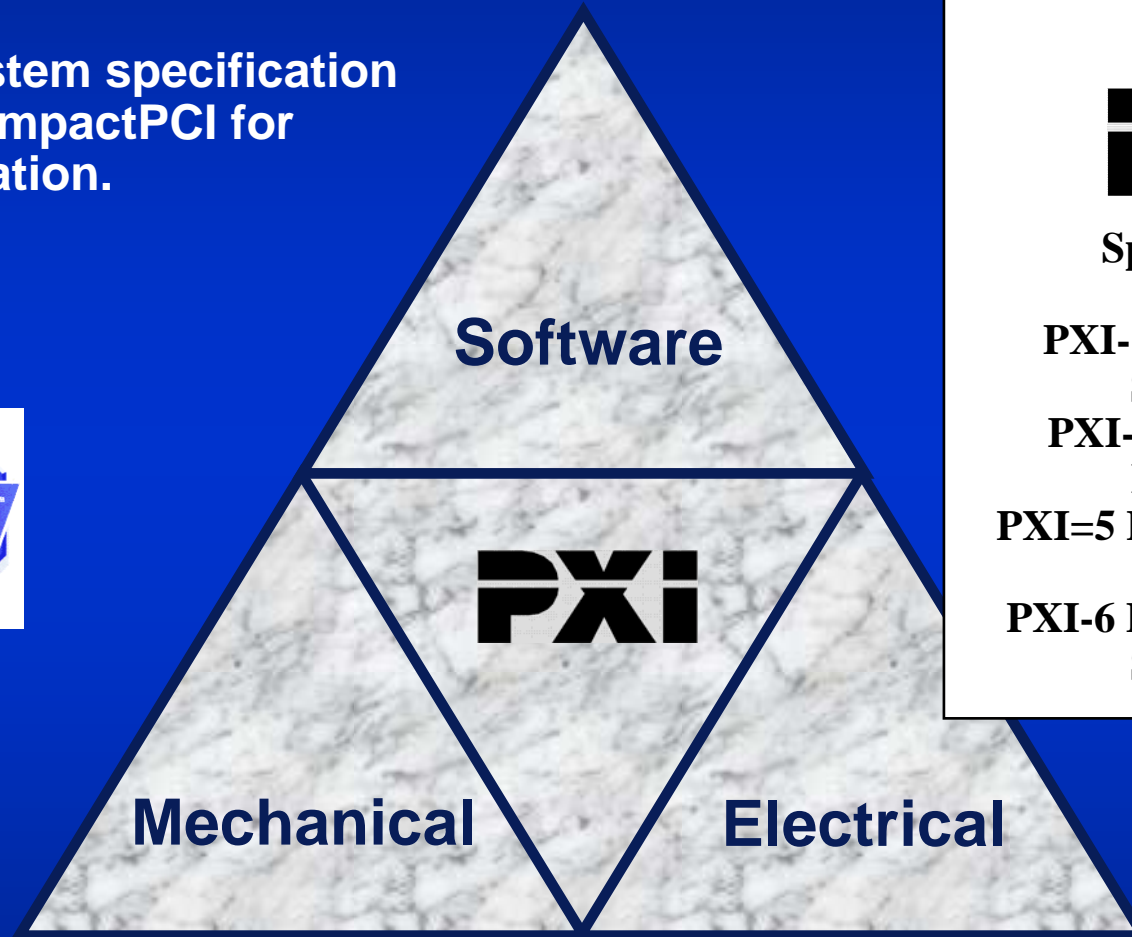

## PXI

Specification

PXI-1 HW Rev. 2.2

Sept 2004

PXI-2 SW Rev. 2.1

Feb. 2003

PXI-5 PXI Express HW

Aug 2005

PXI-6 PXI Express SW

Sept 2005

# PXI

# PXI Architecture Overview

- **PXI/CompactPCI Architecture**
  - Mechanical
  - Electrical
  - Software
- **Built on Open Standards**
  - PICMG
  - PXI Systems Alliance
- **The PXI Specification can be downloaded at [www.pxisa.org](http://www.pxisa.org)**



# PXI Starts with CompactPCI

CompactPCI puts PC technology in a small, rugged package by combining three standards:

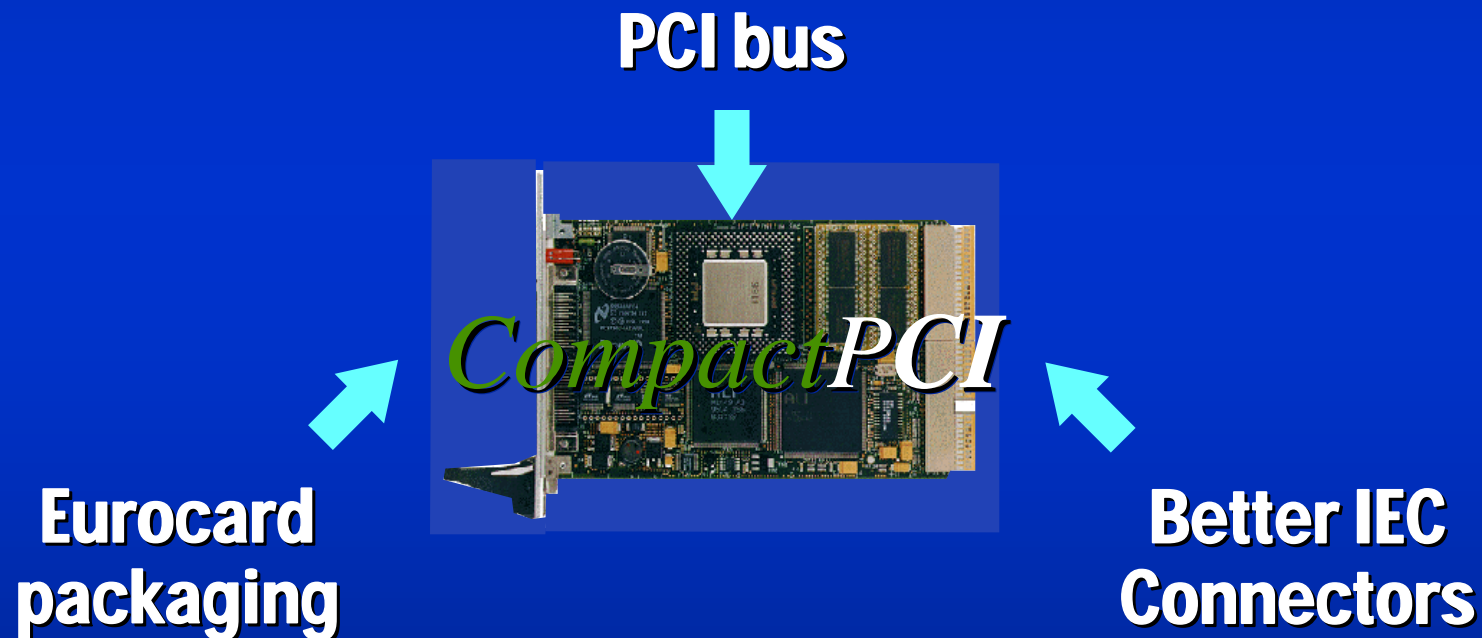

# CompactPCI Starts with PCI, so Why use the PCI bus?

- Wide Industry Support
- 32-bit data transfers at 33 MHz  
(132 Mbytes/sec)
- PCI is a *de facto* PC backplane standard
- CompactPCI = PCI with
  - Industrial Connectors
  - Eurocard packaging



# Why use Different Connectors?

- Higher Pin Count
- Rugged and Reliable
- Integrated Shield
- Impedance Matched
- Most Importantly:  
**MORE SLOTS!**

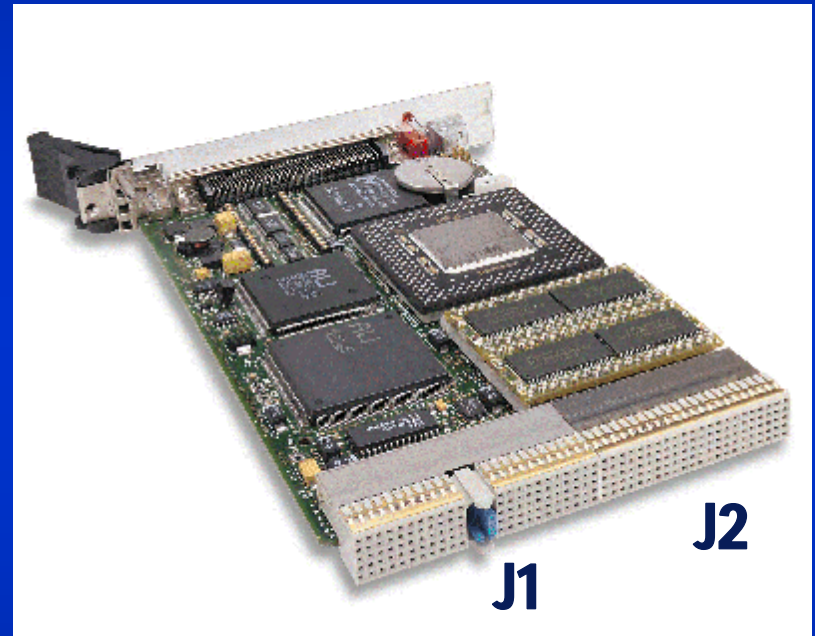

# Why use Eurocard Packaging?

- Proven over decades of use in industrial applications (VME, VXI, etc.)
- Defined by IEEE 1101 Standard
- Readily available mechanical components
- Excellent thermal properties
- Modular, rugged, and compact
- Easily Maintained

**PXI**

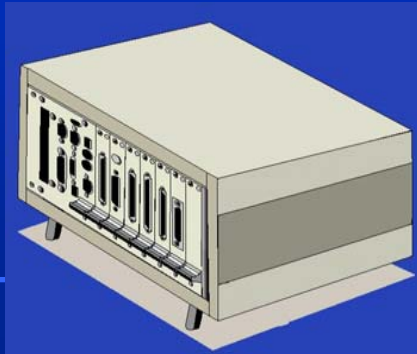

# PC Motherboard = Controller + Backplane

PC Motherboard  
with 4 PCI slots

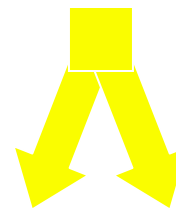
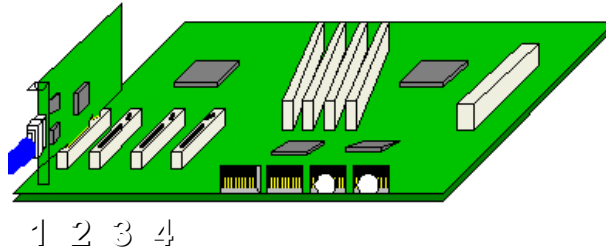

CompactPCI  
8-slot  
or Larger Backplane

CompactPCI  
Embedded  
Controller

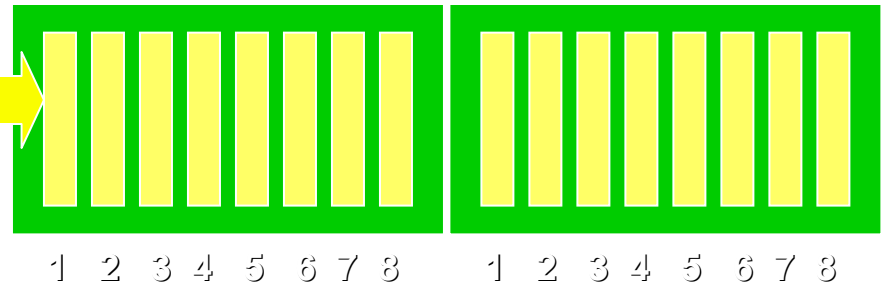

# Peripheral Sizes in PCI and CompactPCI

PCI



PXI/CompactPCI

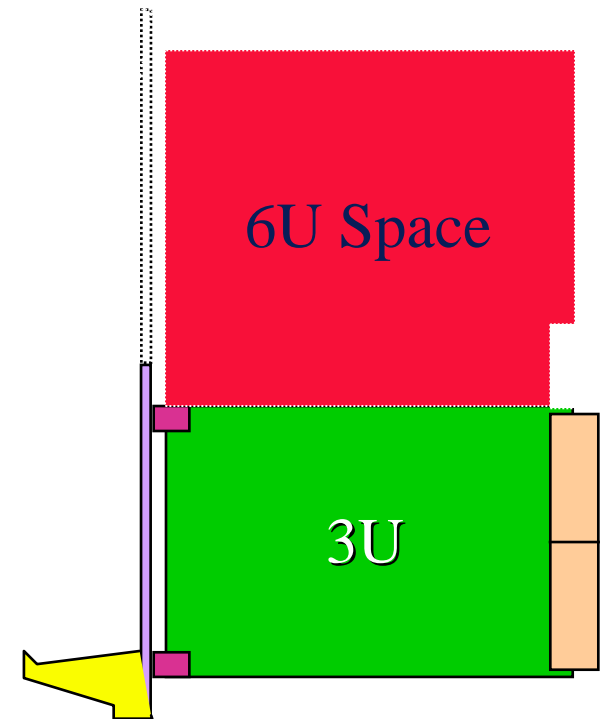

PCI boards can be redesigned to fit in PXI/CompactPCI with little or no electrical changes.

# PXI Starts with CompactPCI and adds “VXI-like” Extensions

- Mechanical Features
- Electrical Extensions
- Software Extensions
- Ability to grow gracefully



# Mechanical Extensions

*PXI improves reliability and interoperability with:*

- **Mandatory Active Cooling**
- **Temperature Testing and Ratings**
- **System-level environmental specifications for EMC, shock, vibration, and humidity**
- **Software Standards**



# Mechanical Features

- CompactPCI combines Eurocard Packaging with High-Performance Connectors and PCI
- All standard PXI connections on J1 & J2
- 3U and 6U electrical compatible
- J3, J4 & J5 for Custom Applications



3U / 6U PXI chassis

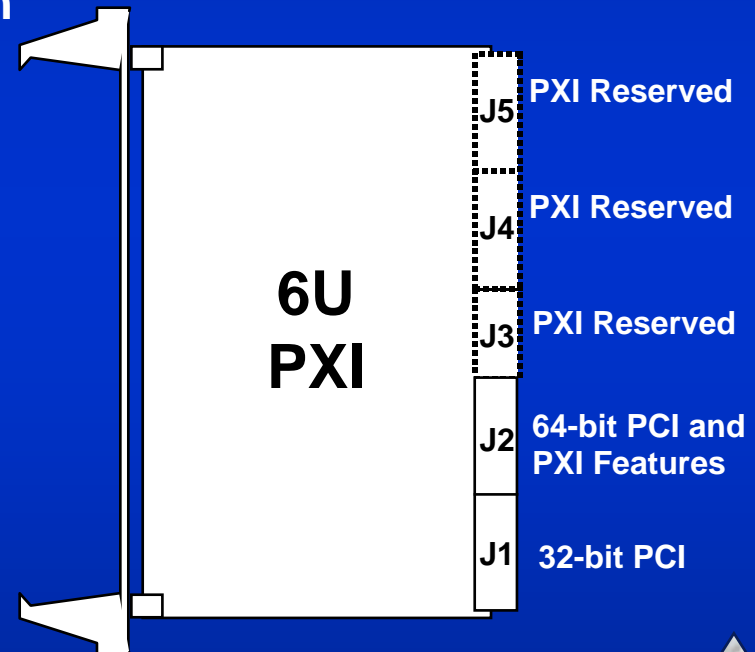
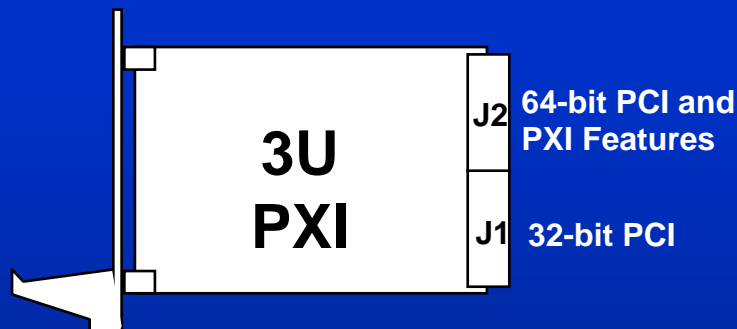

# PXI/CompactPCI Form Factors

- All 3U cards work in 6U systems
  - Mechanical adapter to lock instrument in chassis
- Dual 3U Stacking Option
- Majority of modules in PXI are in 3U form-factor



6U Adapter Panel



Dual 3U Stacking Configuration



# Interoperability and flexibility: 3U & 6U form factors

- Required by PXI Standard
- 6U chassis accept both 3U and 6U instrument modules
- CompactPCI and PMC modules offer another option for building compact test systems

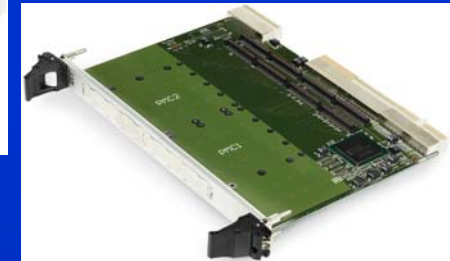

3U Chassis



6U Chassis  
(6U & 3U compatible)



Combined  
3U & 6U



# 6U Instrument Differences

- **6U = Larger Instruments = More Real Estate**
  - More Channels per Slot
  - Higher Bandwidth
  - Localized Intelligence
  - More panel / IO space
- **Can be More Expensive**
  - Choice should be specification dependent
- **3U Devices Also Fit in a 6U Chassis**



# PXI Remote Controllers

- Various versions of remote controllers are available for use with PXI and PXI Express chassis
- Multiple PXI chassis can be interconnected using PCI/PXI and PXI/PXI remote controllers – Star or daisy chained configurations
- PXI-Express remote controllers available for desktop PCs with a PCIe bus.
- Parallel and serial bus implementations



# Remote Controllers

- **MXI-4**
  - 3U PCI to cPCI/PXI remote controller
  - Requires no software, only BIOS support
  - Copper and Fiber Optic cabling available
    - 10 Meters with Copper Cable
    - 30 Meters with Fiber Optic Cable
- **MXI-Express for PXI control**
  - Interfaces between a PCI Express bus and a PXI system slot
- **MXI-Express for PXI Express control**
  - Interfaces between a PCI Express bus and a PXI express slot
  - Available in x1 or x4 configurations



# Electrical Extensions

*PXI timing and triggering improves performance:*

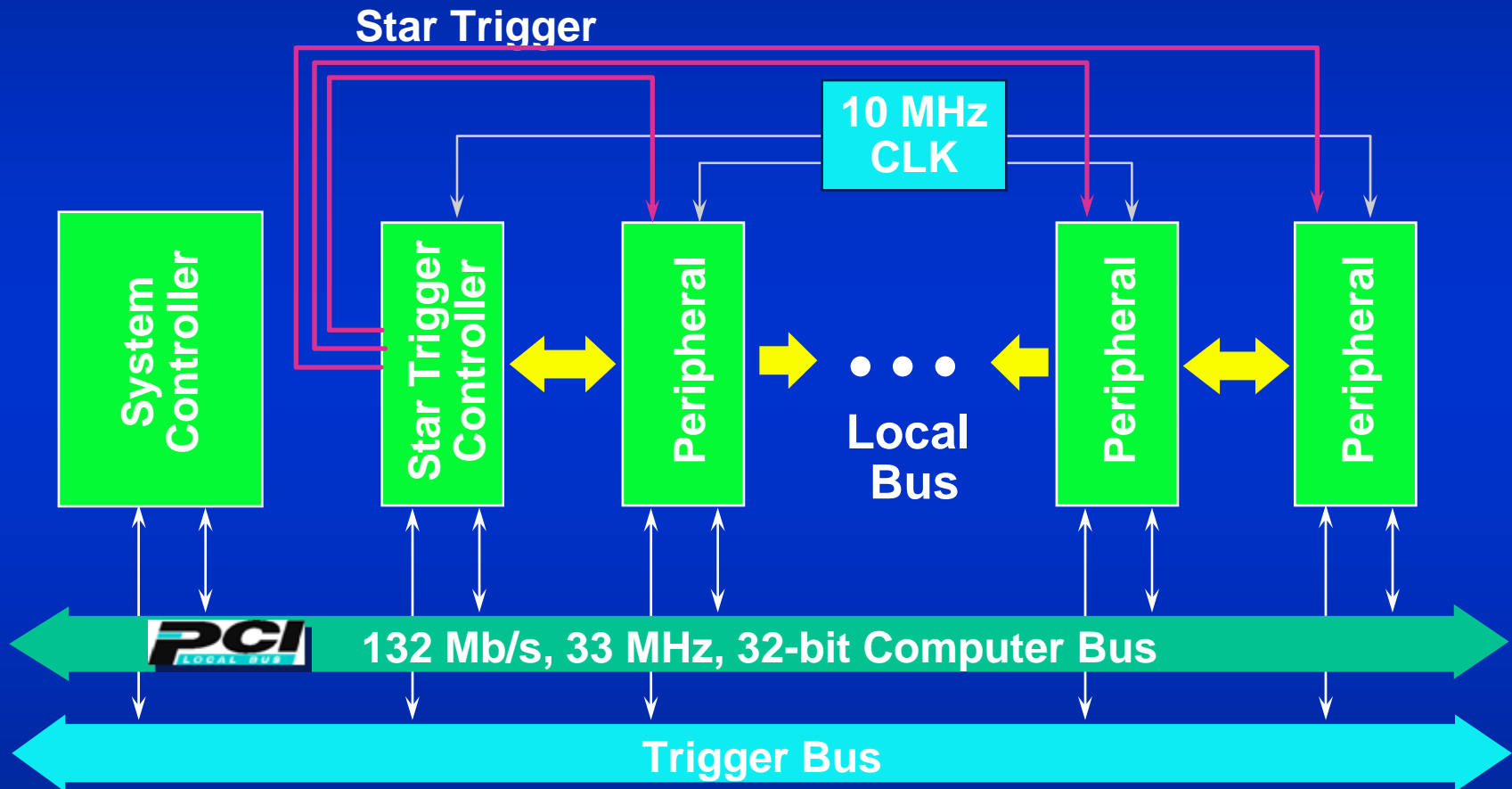

# Multi-Segment Busses

- **PXI/CompactPCI Limited to 7 Peripherals per Bus**
- **“Bridging” – Buffering PCI Signals and PXI Lines Allows for Larger Systems**
- **Up to 21 Instrument Slots in Single 19” Chassis**
  - “Stacked” 3U specification will double that number
- **Clocking Issues – Loss of 1 Clock Cycle per Segment**
  - Timing between modules – try and keep the required instruments in the same segment



# PXI Leverages VXI Features

Timing and Triggering Extensions in PXI and VXI

	<b>Local Bus</b>	<b>Triggers</b>	<b>Clock</b>	<b>Star Bus</b>
<b>VXI</b>	12 lines	8 TTL, 2 ECL	10 MHz ECL	D-size only
<b>PXI</b>	13 lines	8 TTL	10 MHz TTL	1 per slot



# Trigger Bus Synchronizes Modules

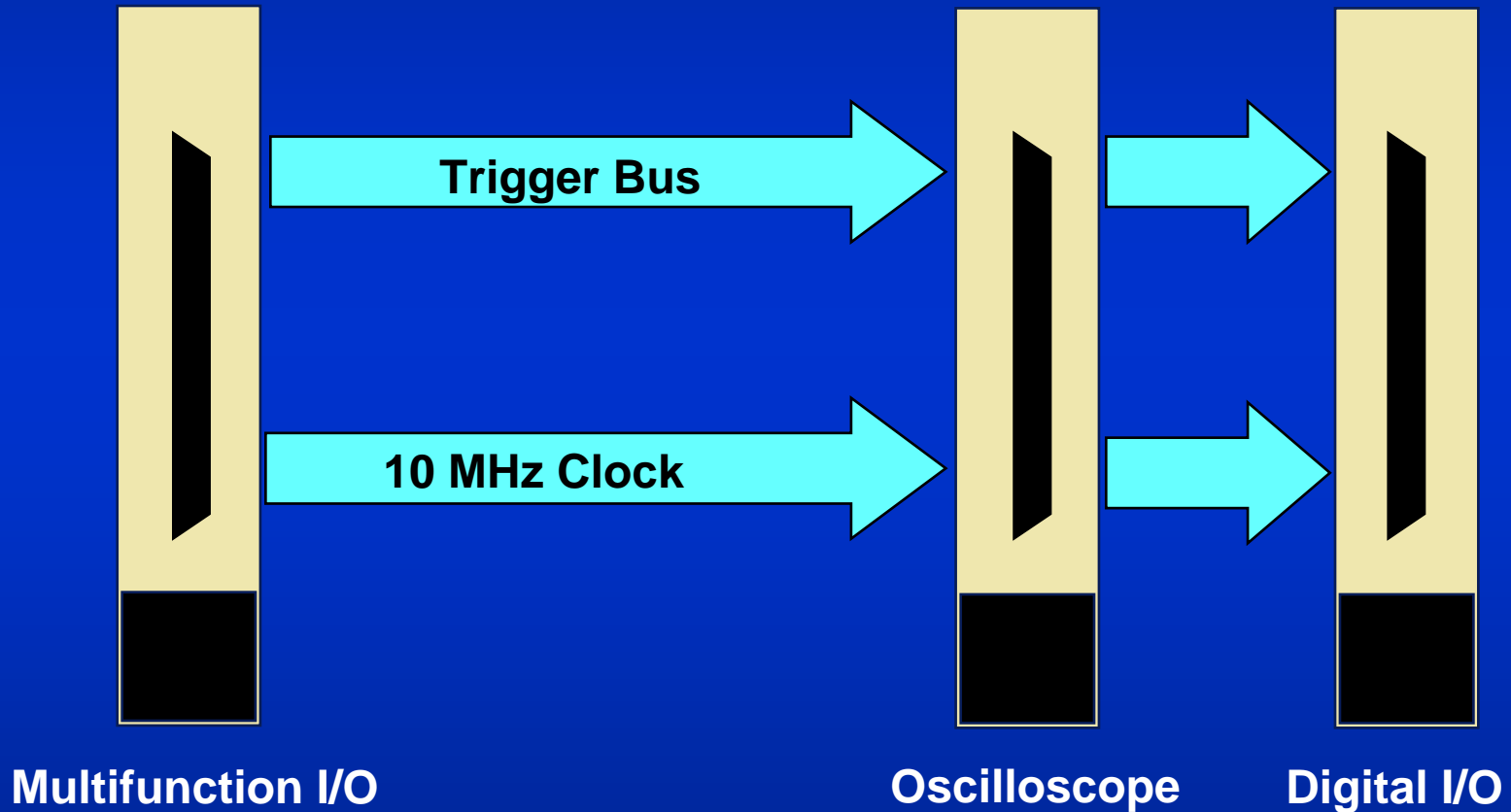

# Software Extensions

*PXI speeds application development because:*

- **PXI Controllers MUST support a Windows standard software framework:**
  - Windows NT/2000/XP/VISTA
  - Windows 9x
- **Peripherals modules MUST be supplied with a WIN32 Device Driver**
- **Other OS Supported Optionally**
  - Linux
  - Qnix



# PXI and PC Software is Compatible

- Operating Systems and Application Software Often Run Unchanged on PXI Systems
- Configuration Tools Recognize PXI Modules As PCI Devices
- Use of PXI Extensions Will Require Additional Programming

*"We ported from a desktop PC to PXI without changing any code" - Len Burczyk,*

*Los Alamos National Laboratories*



# PXI Architecture Summary

PXI Builds on CompactPCI to define complete Measurement and Automation Systems



Systems



Components

**PXI**

Electrical

Software

Mechanical

*CompactPCI*

PCIbus

EuroCard

High Performance  
Connectors

# The CompactPCI Specification Body



## PCI Industrial Computer Manufacturers Group

- Governs the core CompactPCI specification
- Focus is on telecommunications infrastructure
- Online product directory contains 100s of products
- Over 500 company members



[www.picmg.org](http://www.picmg.org)

# The PXI Specification Body



- Charter of this group is to:
  - Promote PXI
  - Ensure Interoperability
  - Control the PXI Specification
- Focus is on **end-user success** in measurement and automation
- Over 50 company members



[www.pxisa.org](http://www.pxisa.org)

# **PXI Systems Alliance Sponsor Members**

- **ADLINK Technology**
- **Gigatronics**
- **Geotest – Marvin Test Systems**
- **National Instruments**
- **Pickering Interfaces**
- **Teradyne**
- **Aeroflex**



# Other PXI Systems Alliance

## Members

- Acculogic
- Advantech
- Agilent Technologies
- AIM-USA
- Alfautomazione
- Amplicon
- Applicos bv
- Aversa
- Bloomy Controls
- CHROMA ATE
- Conduant Corporation
- Data Device Corp
- DiagnoSYS Systems
- Dow-Key Microwave
- Goepel Electronic
- Huntron
- JTAG Technologies
- Keithley Instruments
- KineticSystems/Gage Applied Technologies
- Konrad Technologies
- MAC Panel
- Meilhaus Electronic Gmbh
- MEN Mikro Elektronik
- Mindready Solutions
- Nextronics
- One Stop Systems
- Phase Matrix, Inc.
- PLX Technology
- PXIdirect Gmbh
- Ranatec Instrument AB
- Rohde and Schwarz
- SIGNAMETRICS
- Spectracom
- Spectrum Gmbh
- Strategic Test AB
- Sundance
- TEGAM, Inc.
- Tracewell Systems
- TZ Mikroelektronik
- Viewpoint Systems
- Virginia Panel Corp.
- VXinstruments Gmbh
- XIA LLC
- ZTEC



# PXI Modules Link to Other Standards

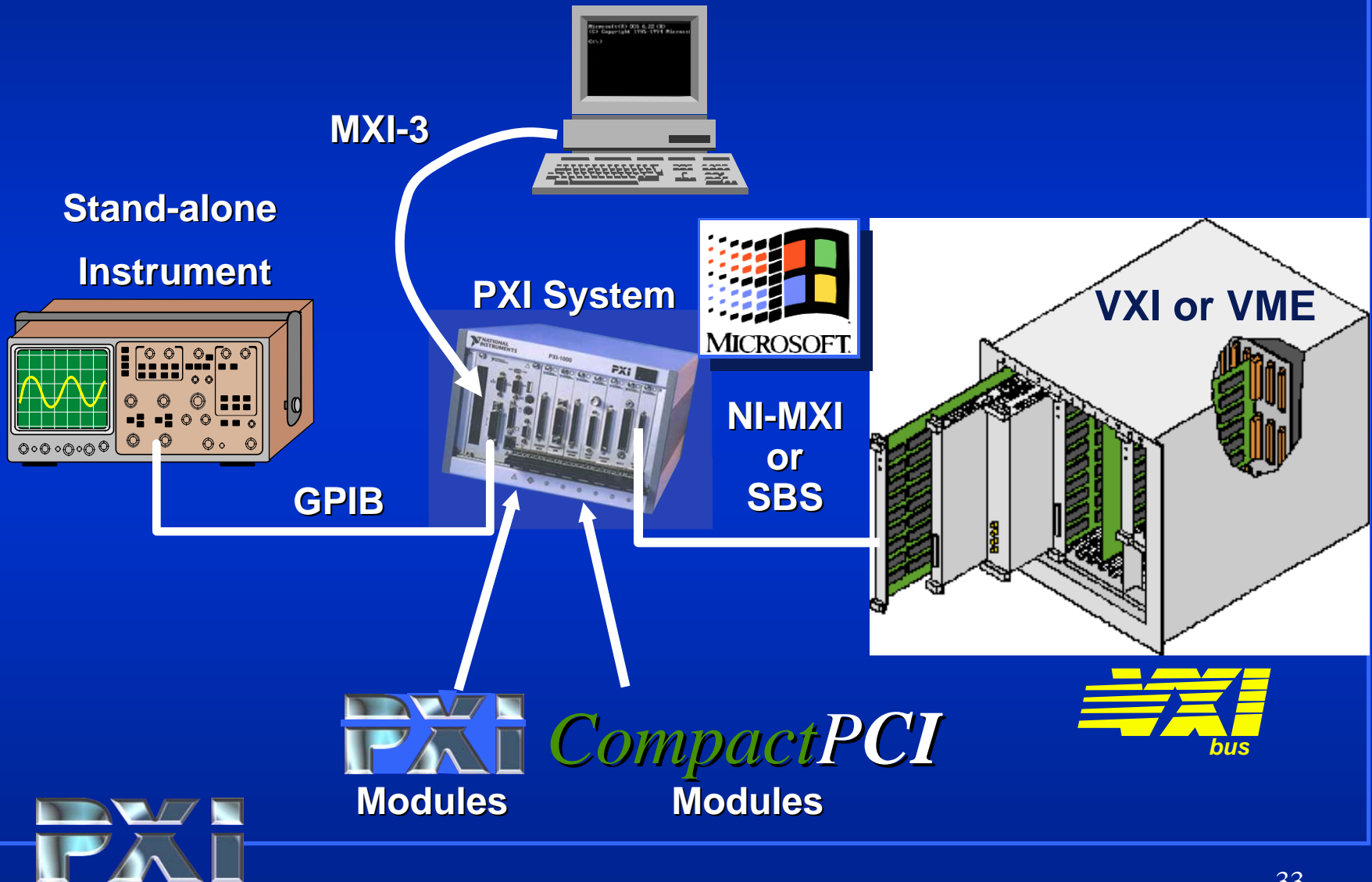

**PXI**

# Many Third-party Information Sources

- Magazine, Newsletter and Catalog
- Use online directories
  - [www.pxisa.org](http://www.pxisa.org)
  - [www.picmg.org](http://www.picmg.org)
  - [www.pxionline.com](http://www.pxionline.com)

# PXI Market

Available PXI Products

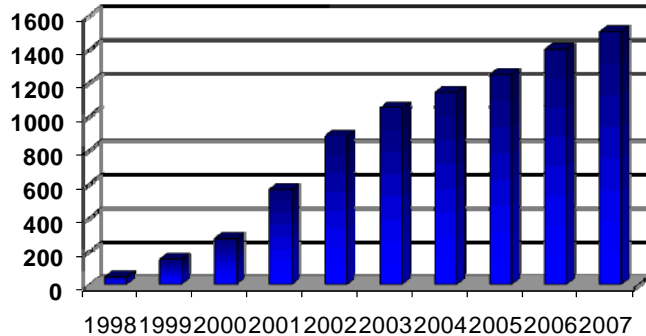

More than 1,500 PXI Products from 60 vendors

*Source: PXI Systems Alliance*

PXI Sales 2006: \$258M\*

PXI Sales growth: 14% CAGR, 2005 - 2011

\* Prime Data March 2008

*Source: World VXI & PXI Test Equipment Markets, Frost & Sullivan, April 2005*

PXI vs VXI Systems Sales Forecast

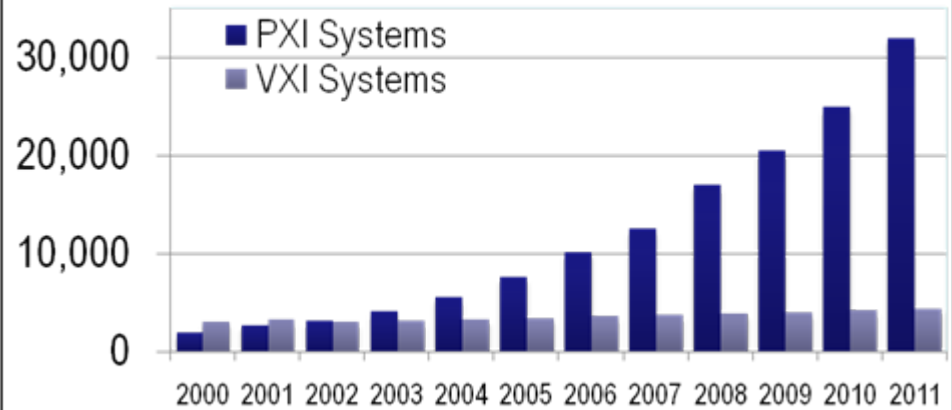

# Summary

- **Longevity and success as a standard**
  - Well accepted in diverse applications and industries for low-cost, modularity, ease of use, and performance.
  - The PXI specification is 11 years old. From a single company in 1997 to ~ 50 companies and over 1,500 products, PXI can address the most complex application.
- **Standard continues to evolve with backward compatibility**
  - PXI => PXI Express, for example
- **Strong promotional campaign continues**
  - New PXI multi-vendor demo in Booth #330
  - Re-designed website

